



Tenditore alluminio tipo ST721

Aluminium wardrobe adjuster ST721 type

FISSAGGIO SENZA VITI
DENSITA' LINEARE 805
g/m
LUNGHEZZA: MIN 1200
MAX 2800
L'ASSENZA DI VITI EVITA
LA FORMAZIONE DI
FORZE DI AUTO
TENSIONAMENTO.

SCREWLESS FIXING
LINEAR DENSITY 805 g/m
LENGTH: MIN 1200 MAX
2800.
THE ABSENCE OF
SCREWS PREVENTS THE
FORMATION OF SELF-
TENSIONING FORCES.

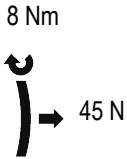

test indicativo su
lunghezza 2580
indicative test on
2580 length



fermo di posizione
stop device cover
Cod.: P.A372.00

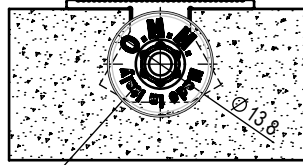
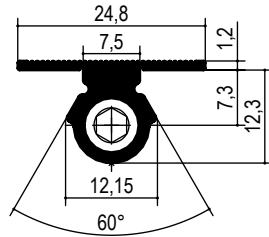

A) fermo di posizione a richiesta
A) stop-device position on demand

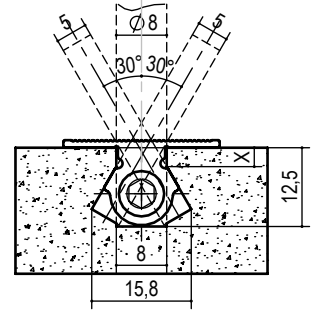

lavorazione con 3 frese a
disco in linea. DXF a richiesta.
3 in line milling operations
DXF on request.

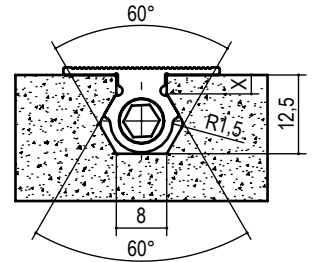

lavorazione con fresa in
sagoma. DXF a richiesta.
in shape milling operation
DXF on request

X= 3 per finitura anodizzato
X= 2.5 per finitura verniciato
X= 3 for anodised finishing
X= 2.5 for painted finishing

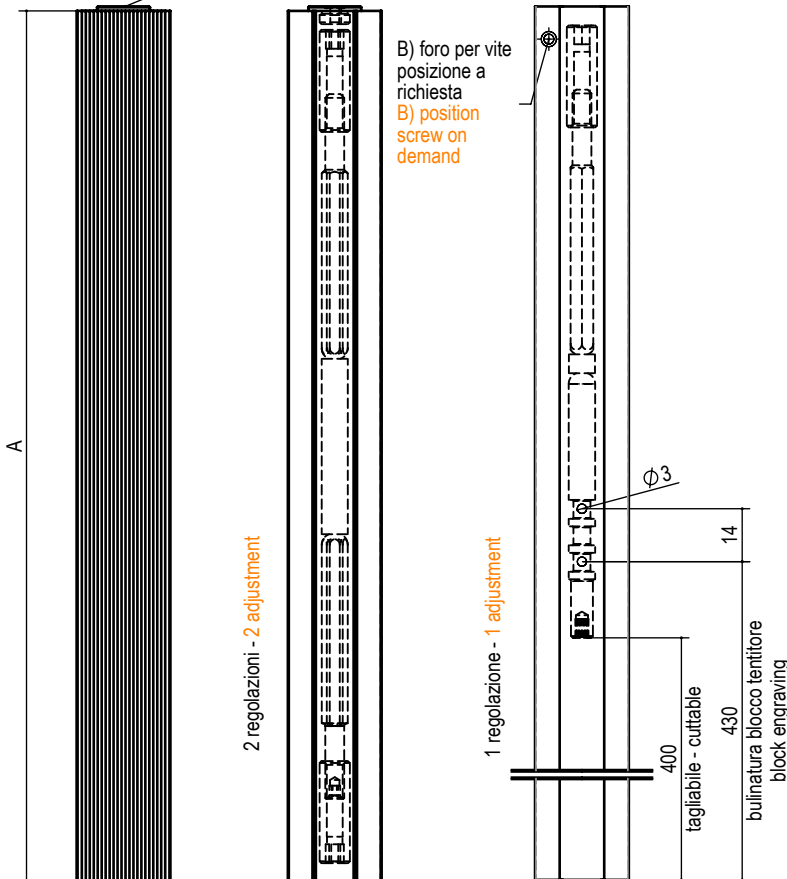

tipo type	misura measure	finitura finishing	tagliabile cuttable
ST721	A a richiesta on request	00 grezzo - crude 12 anodizzato ARC - anodised altre finiture a richiesta - other finishings on request	TG

es./e.g.: ST721.A.00
es. codice tagliabile/e.g. cuttable code: ST721.A.00.TG